

REV.	CHANGE CONTENT	BY	DATE

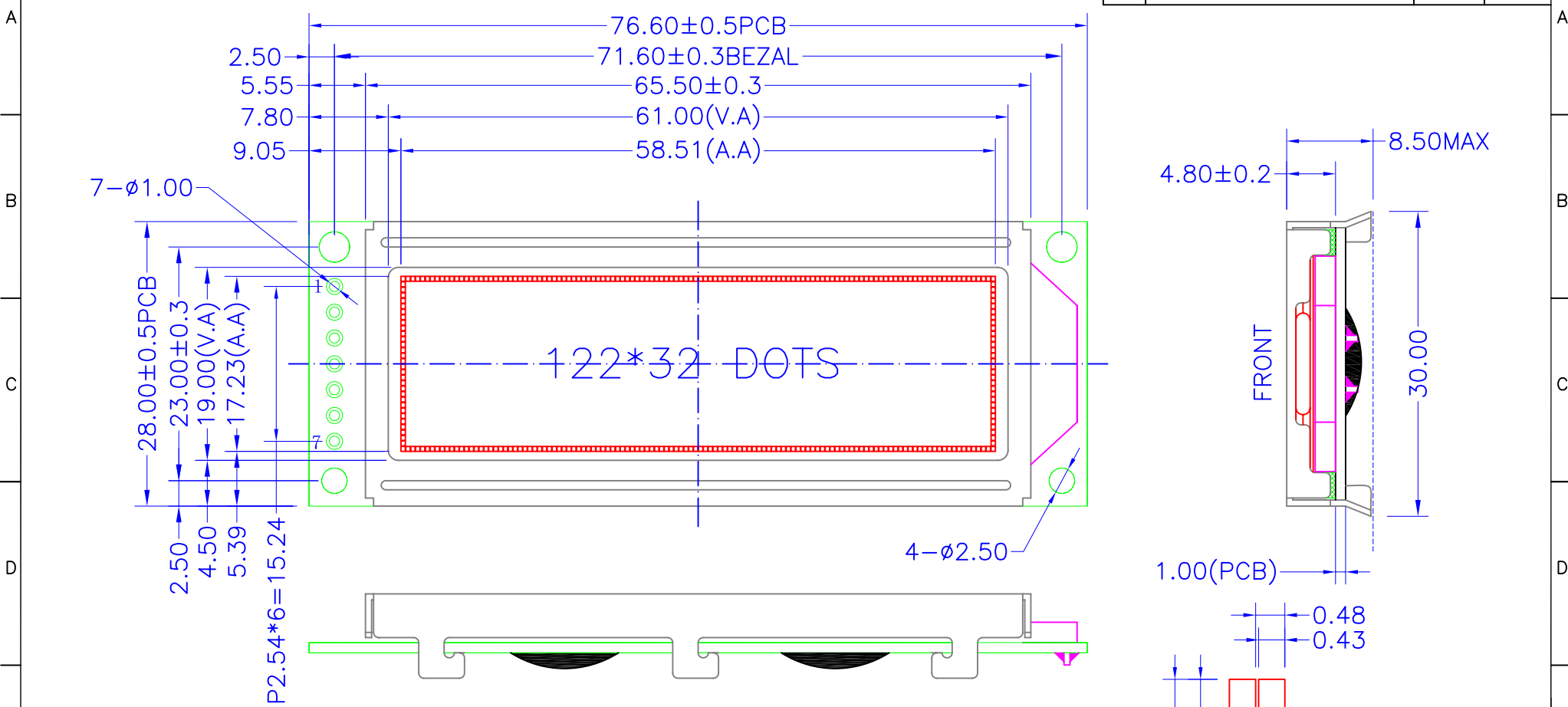

NOTE:

1. LCD TYPE: STN-BLUE-NEGATIVE
2. POLARIZER MODE: TRANSMISSIVE
3. DRIVE METHOD: 1/32 DUTY, 1/5 BIAS, Vop=7.5V
4. VIEWING DIR.: 6:00
5. OP. TEMP.: -20°C~70°C
6. ST. TEMP.: -40°C~85°C
7. BACKLIGHT: WHITE, Vf=5.0V, If<30mA
8. LCD CONTROLLER: ST7920-0B, VDD=5.0V

PIN DESCRIPTION:

1	2	3	4	5	6	7
VSS	VDD	CS	SID	SCLK/RST	LED+	

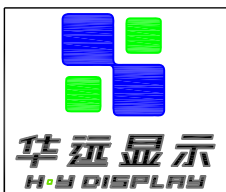

深圳市华远显示器件有限公司
SHENZHEN HUAYUAN DISPLAY CO., LTD

DRAWING No.: HYG1223209C-bT62L-VE
DRAWING TITLE: LCM
FILE NO.: 8

DESIGN		STANDARD	
CHECKED		TECHNOLOGY	
APPROVED		Q. A	

REV.: A	SCALE: -
PROJECTION:	UNIT: MM
	SHEET: 1/1